

NENNWEITE	NENNDRUCK	FLANSCH EN 1092-1	WASSERPRÜFDRUCK
DN	bar	PN	bar
40 - 1600	10	10	15
40 - 1600	16	16	24
40 - 1200	25	25	37,5

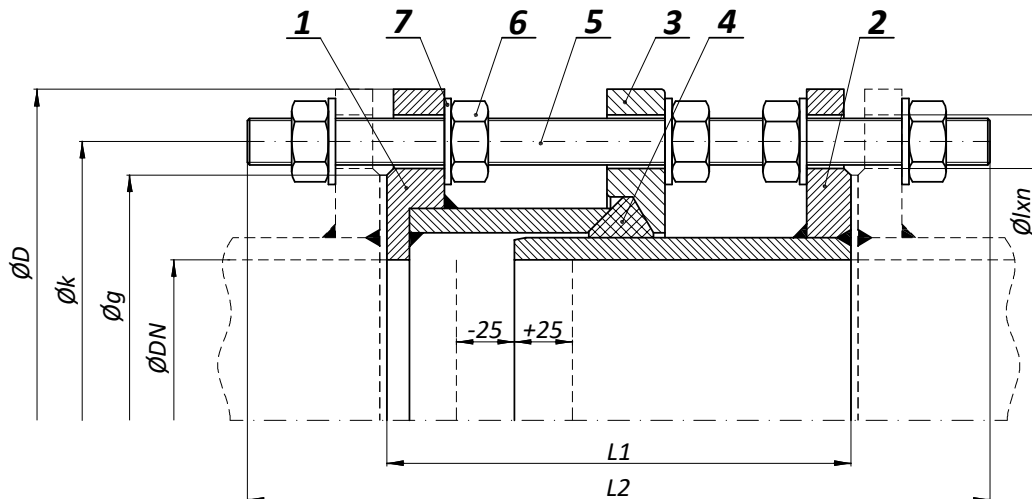

TEIL	WERKSTOFF NACH EN
1	S355J2+N
2	S355J2+N
3	S355J2+N
4	EPDM
5	A4
6	8 galvanisiert
7	St galvanisiert

Andere Werkstoffe auf Anfrage

VERWENDUNG: WASSER, TRINKWASSER, ABWASSER

MAX. BETRIEBSTEMPERATUR: 60°C (Andere auf Anfrage)

Standard Beschichtung: C4H nach ISO 12944 (andere auf Anfrage)

Andere Medien auf Anfrage

DN	40	50	65	80	100	125	150	200	250	300	350	400	450	500	600	700	800	900	1000	1100	1200	1300	1400	1500	1600	
PN 10	D	150	165	185	200	220	250	285	340	395	445	505	565	615	670	780	895	1015	1115	1230	1340	1455	1575	1675	1785	1915
	k	110	125	145	160	180	210	240	295	350	400	460	515	565	620	725	840	950	1050	1160	1270	1380	1490	1590	1700	1820
	g	88	102	122	138	158	188	212	268	320	370	430	482	532	585	685	800	905	1005	1110	1215	1330	1438	1535	1640	1760
	n	4	4	4	8	8	8	8	8	12	12	16	16	20	20	20	24	24	28	28	31	32	32	36	36	40
	l	18	18	18	18	18	18	22	22	22	22	26	26	26	30	30	33	33	36	36	39	42	42	42	42	48
	L ₁	180	180	180	200	200	200	200	220	220	220	230	230	250	260	260	260	290	290	290	300	320	340	360	380	390
	L ₂	280	280	280	310	310	310	320	340	360	360	370	390	390	410	410	460	460	480	480	520	530	560	590	600	
	m kg	9	11	13	17	21	26	35	49	64	73	96	124	141	160	207	259	354	407	488	589	748	914	1037	1162	1525
PN 16	D	150	165	185	200	220	250	285	340	405	460	520	580	640	715	840	910	1025	1125	1255	1355	1485	1585	1685	-	1930
	k	110	125	145	160	180	210	240	295	355	410	470	525	585	650	770	840	950	1050	1170	1270	1390	1490	1590	-	1820
	g	88	102	122	138	158	188	212	268	320	378	438	490	550	610	725	795	900	1000	1115	1218	1330	1438	1530	-	1750
	n	4	4	4	8	8	8	8	12	12	12	16	16	20	20	20	24	24	28	28	32	32	32	36	-	40
	l	18	18	18	18	18	18	22	22	26	26	26	30	30	33	36	36	39	39	42	42	48	48	48	-	56
	L ₁	180	180	180	200	200	200	200	220	230	250	260	270	280	300	300	320	320	340	340	340	360	370	380	-	-
	L ₂	280	280	280	310	310	310	320	340	370	410	410	430	430	440	480	480	520	520	560	560	600	610	630	-	-
	m kg	9	11	13	18	21	26	35	52	76	93	129	164	190	243	332	368	480	548	719	813	1110	1226	1350	-	-
PN 25	D	150	165	185	200	235	270	300	360	425	485	555	620	670	730	845	960	1085	1185	1320	-	1530	-	-	-	-
	k	110	125	145	160	190	220	250	310	370	430	490	550	600	660	770	875	990	1090	1210	-	1420	-	-	-	-
	g	88	102	122	138	162	188	218	278	335	395	450	505	555	615	720	820	930	1030	1140	-	1350	-	-	-	-
	n	4	4	8	8	8	8	8	12	12	16	16	16	20	20	20	24	24	28	28	-	32	-	-	-	-
	l	18	18	18	18	22	26	26	26	30	30	33	36	36	36	39	42	48	48	56	-	56	-	-	-	-
	L ₁	190	200	200	210	220	220	230	230	250	250	270	280	280	300	320	340	360	380	400	-	450	-	-	-	-
	L ₂	310	310	310	330	340	370	370	370	410	410	440	480	480	480	520	530	600	600	650	-	720	-	-	-	-
	m kg	10	13	18	22	32	43	52	76	103	134	196	248	281	327	436	573	800	888	1272	-	1870	-	-	-	-